

tungsten carbide coated wheels

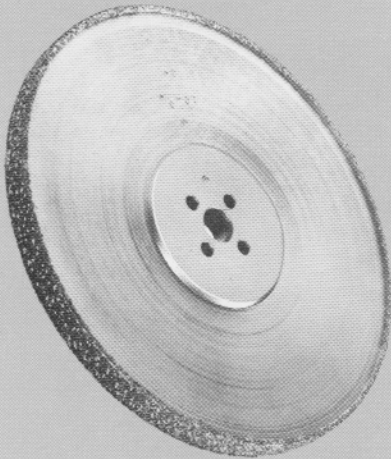

outsole/insole roughing and reducing

FOR USE ON INDUSTRIAL SHOE MACHINERY OR COMPO SHOE MACHINERY EQUIPMENT.

These wheels are available for replacement on standard outsole/insole roughing and reducing machines. Used wheels can be regritted with our exclusive tungsten carbide coating.



DIA.	WIDTH	ARBOR
10"	3/4"	3/4"

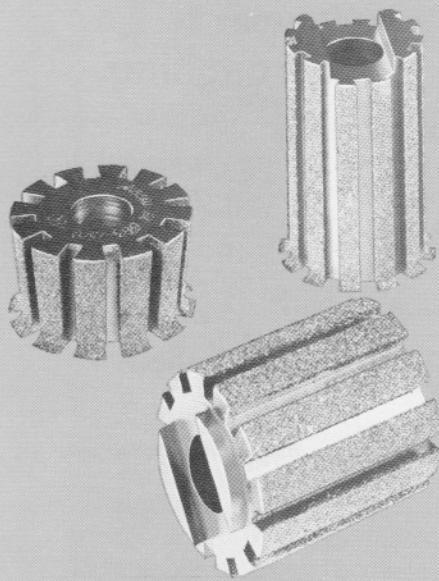

cutters available for ALBEKO, USM, and similar machines

These high speed cutters are available in a wide variety of grit sizes, wheel heights and lip radii in both fluted and solid design.

DIA.	HEIGHT	ARBOR
2"	Specify	3/4"

Specify Machine

Please contact your PCI representative for details.



heel breasters

These heel breasting wheels provide a superior service over conventional coated abrasives. Features include long life and no replacing or recovering of felt wheels. Available in standard grit sizes: 24 grit, 36 grit. Specify heel breaster die shape or send sample with order. Also specify bore and the machine to be used on.